

ADVANCE®

Model 480

Gas Chlorinator

Severn Trent Services developed the all-vacuum gas feeders which have become the worldwide standard.

Model 480 gas chlorinators are designed for manual or semi-automatic gas regulation.

Easy to install, for indoor or outdoor installation, each Model 480 chlorinator is factory tested and needs no field adjustment prior to start-up. Five different flowmeter capacities provide versatility in meeting gas flow requirements. Chlorinators mount directly on the gas valve of a cylinder utilizing a lead gasketed positive yoke clamp. Diaphragm ejectors are standard with a choice of diffuser outlets. As an option, a variety of different ejectors are available to meet your application needs.

A Model 480 chlorinator consists of a vacuum regulator, ejector or chemical induction unit and vacuum and vent tubing to make a complete system. If multiple feed points are required, remote meter panels and additional ejectors are provided. A switchover module is offered to provide for uninterrupted service.



- ◆ Safe and reliable all-vacuum operation
- ◆ Worldwide standard for chlorinator technology
- ◆ Superior materials of construction for wet or dry gas service
- ◆ Safe integral venting system
- ◆ Five capacities up to 100 PPD (2 kg/h)
- ◆ Solid silver rate and inlet valves
- ◆ Direct cylinder mounted
- ◆ Replaceable inlet capsule
- ◆ Remote metering available
- ◆ Optional switchover capability with automatic reset for uninterrupted service

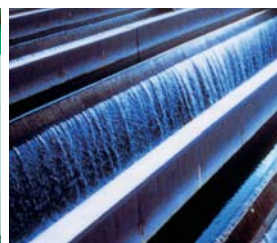

CHEMICAL INDUCTION UNITS

Severn Trent Services CHLOR-A-VAC® Series 1420 chemical induction units offer improved chlorination and dechlorination through the high-efficiency mixing of gaseous chemical with process water. This translates into operating and chemical cost savings.

CHLOR-A-VAC® units produce a vacuum when process water passes through water inlet ports and through a venturi. The high vacuum and recessed impeller create great turbulence and complete chemical mixing.

A chemical induction unit in lieu of an ejector should be considered for the following applications: contact basins, headwater, return sludge processes, clarifier inlets, collection basins, equalization tanks and clear wells. (Refer to Bulletin 130.0001)

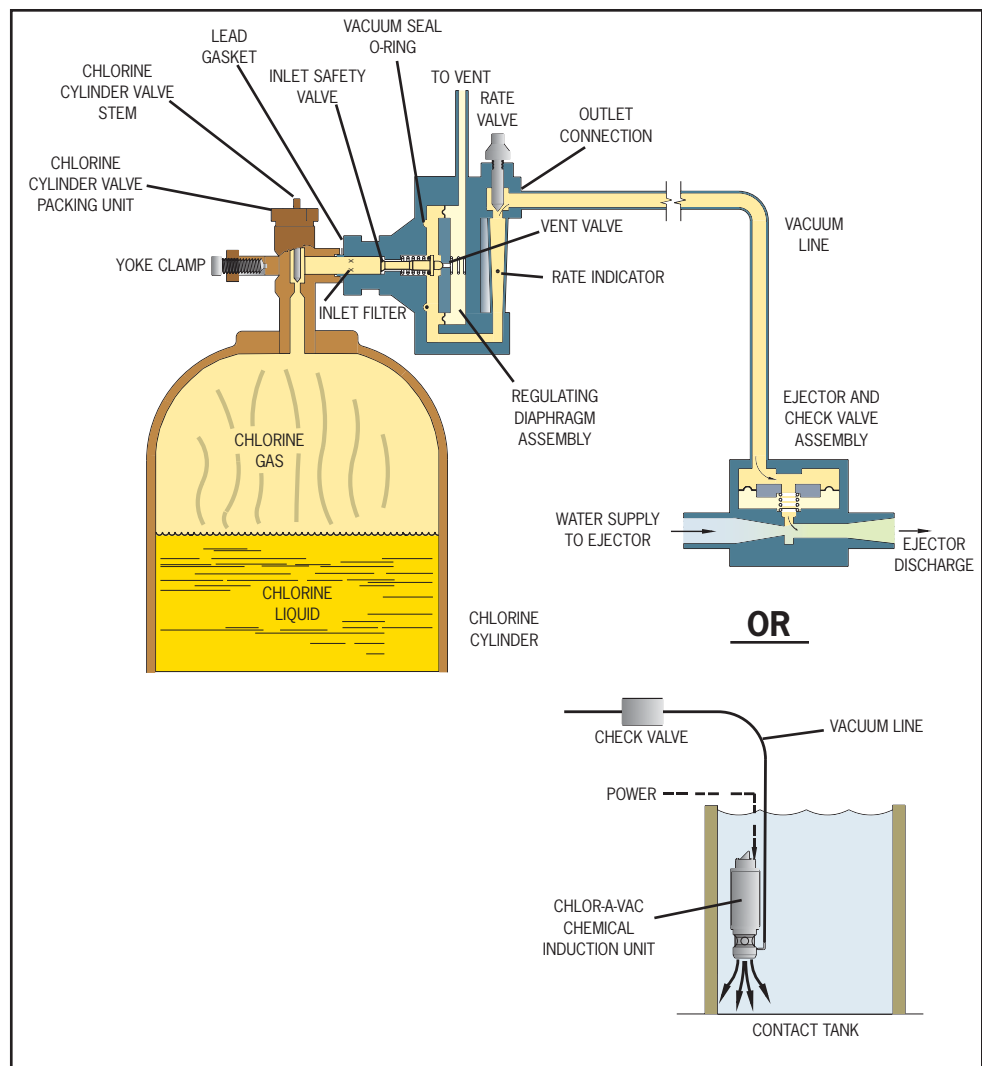

Figure 1 - Cylinder Mounted Chlorinator Flow Diagram

DESIGN FEATURES

- ◆ Sonic Flow: Gas flows at sonic velocity maintaining constant gas flow; additional pressure regulation is not required.
- ◆ Automatic Switchover: A separate, independent device that does not require manual reset. Flow indication is available at both vacuum regulators. Each vacuum regulator has a separate independent vent and an integral pressure relief device.
- ◆ Reliable: Over 35 years of experience with all vacuum operation, loss of chlorine supply indicator, integral venting system, double-thickness main regulating diaphragm, integral gas flow indicator.
- ◆ Ease of maintenance: Simplicity of design and modularized components; such as the replaceable inlet capsule for minimized maintenance.
- ◆ Superior materials of construction: Solid silver rate valve, corrosion resistant yoke assembly, tantalum springs.

APPLICATIONS

For process water, waste treatment and water treatment in the municipal or industrial marketplace:

- ◆ Potable water disinfection, well water, surface water plants
- ◆ Slime and algae control: irrigation systems, cooling towers, rechlorination points, remote systems
- ◆ Wastewater disinfection: packaged plants, lagoons, industrial effluents
- ◆ Process water: chemical and pharmaceutical manufacture, food (washdown, canning, bleaching, taste and odor control)
- ◆ Cyanide, chromium removal: metal finishing wastes
- ◆ Recreation water: swimming pools, fountains, spray ponds

TECHNICAL DATA

Quality Standard: ISO 9001

Capacities: Standard dual-rate indicating flowmeters are available with the following capacities: 4, 10, 25, 50, 100 PPD (75, 200 g/h, 0.5, 1, 2 kg/h) of chlorine gas.

Flowmeter: The minimum feed capacity for every gas flowmeter is 1/20th of the maximum capacity. Accuracy is within $\pm 4\%$ of maximum flowmeter capacity.

OPERATION

Vacuum System

Water flowing through the ejector venturi, creates a vacuum which opens the check valve in the ejector. The vacuum is carried through the vacuum line to the vacuum regulator where the pressure differential created causes the inlet valve at the vacuum regulator to open, initiating gas flow. A spring opposed diaphragm in the vacuum regulator, regulates the vacuum. The gas passes under vacuum through the flowmeter, the rate control valve, the vacuum line and to the ejector. Here the gas is thoroughly mixed with water and applied as a solution (Figure 1).

The system is completely under vacuum from each ejector to the vacuum regulator inlet safety valve. If the water supply to any ejector stops or vacuum is lost for any other reason, the spring loaded inlet valve immediately closes and isolates the gas supply. If the gas source is depleted, the unit seals to prevent moisture from being drawn back into the gas source. When more than one feed point is desired multiple flowmeters and ejectors can be supplied.

Model

4 8 1 C

Maximum Capacity

1 - 100 PPD/2 kg/h

Gas Handled

C - Chlorine

Vacuum Regulator Mounting

1 - Cylinder or manifold mounted with rate valve

3 - Cylinder or manifold mounted with remote meter(s) and rate valve

AUTOMATIC SWITCHOVER

For uninterrupted gas feeding on a round-the-clock basis, an automatic switchover system is required. Each system consists of two vacuum regulators, one vacuum type automatic switchover module, one ejector and one remote meter panel. An automatic switchover module allows gas to flow under vacuum from the regulator in service through the switchover module to the remote meter panel and the ejector, until that source is depleted. The vacuum sealing valve on the regulator then closes and the vacuum level in the system increases, initiating the spring-loaded toggle assembly in the switchover module. (Figure 2) The open valve on the depleted source closes while the valve on the standby source opens to permit gas flow. When a fresh gas supply replaces the depleted source it will automatically be placed in standby. The fresh supply will not be accessed until the supply in service is exhausted.

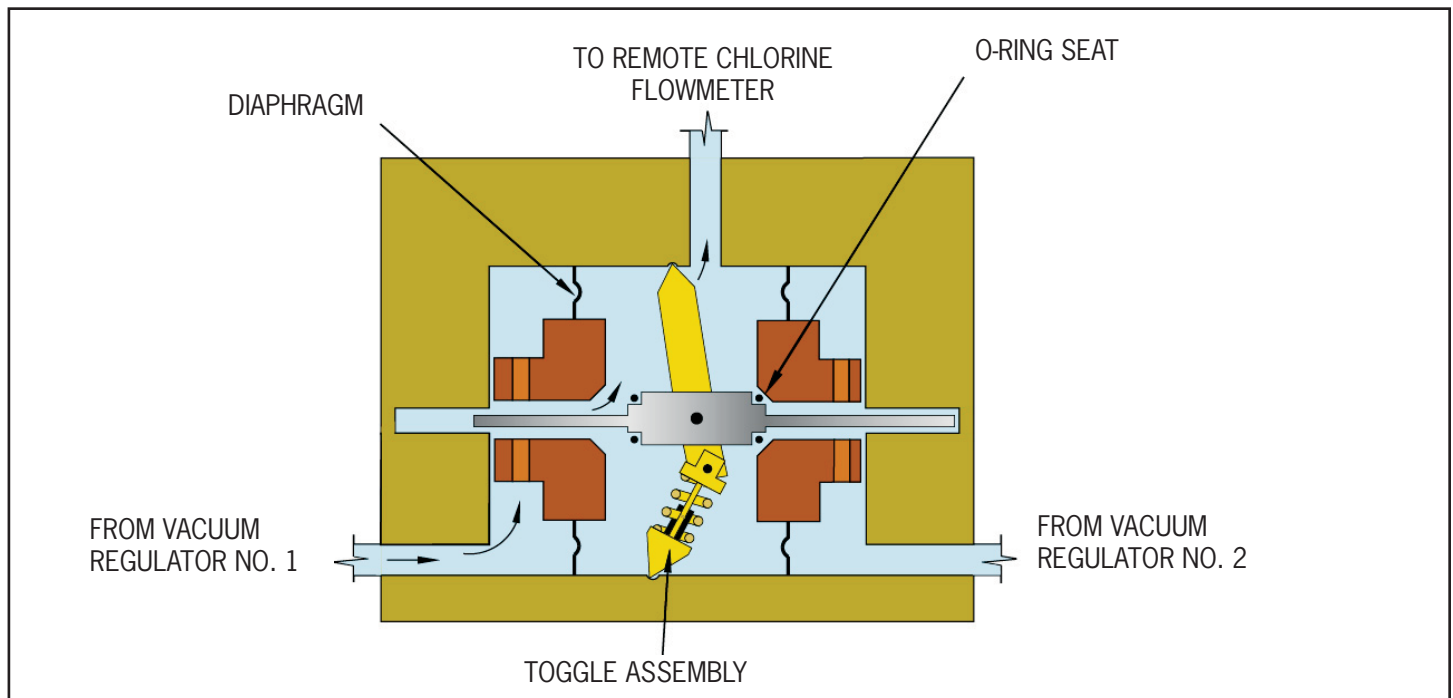

Figure 2 - Automatic Switchover Flow Diagram

Warranty and Capability

Severn Trent Services offers a limited three (3) year warranty on the Model 480 chlorinator and a limited lifetime warranty on the springs and Halar diaphragm.

Severn Trent Services is ISO 9001 certified to provide quality and precision materials. Disinfection technologies, water quality monitors and instrumentation for water and wastewater are areas of specialization. Over 35 years of industrial and municipal application experience in the water and wastewater industries is incorporated into the equipment design to provide high quality comprehensive solutions for the global market.

Brief Specification

The chlorinator design shall be of the vacuum operated, solution feed type. The chlorinator shall be constructed of materials suitable for wet or dry gas service. All springs used in the vacuum regulator shall be of tantalum alloy. The rate valve and seat shall be solid silver. A double-thickness diaphragm shall be provided for vacuum regulation. The rate of gas feed shall be set manually and shall remain constant until manually changed. The gas shall flow at sonic velocity and a differential pressure regulator shall not be required.

The vacuum regulator shall mount directly on the container valve by means of a corrosion resistant yoke assembly. A spring-opposed inlet valve shall close tight upon loss of vacuum. Each vacuum regulator shall be equipped with a loss-of-gas indicator, and a gas flowmeter. A spring-loaded diaphragm actuated pressure relief valve integral to the vacuum regulator shall be provided to relieve gas pressure. The inlet capsule shall be a complete module, installed without the use of any tools.

The vacuum producing device shall be an ejector with a spring-loaded check valve to prevent flooding of the vacuum regulator or a CHLOR-A-VAC® chemical induction unit, Series 1420.

Automatic switchover shall be provided with automatic reset and integrally mounted vacuum regulator flow indicator.

The chlorinator shall be Severn Trent Services ADVANCE® Model 481C.



Option: VEGA - Vent Exhaust Gas Arrestor

Refer to product bulletin 141.0001

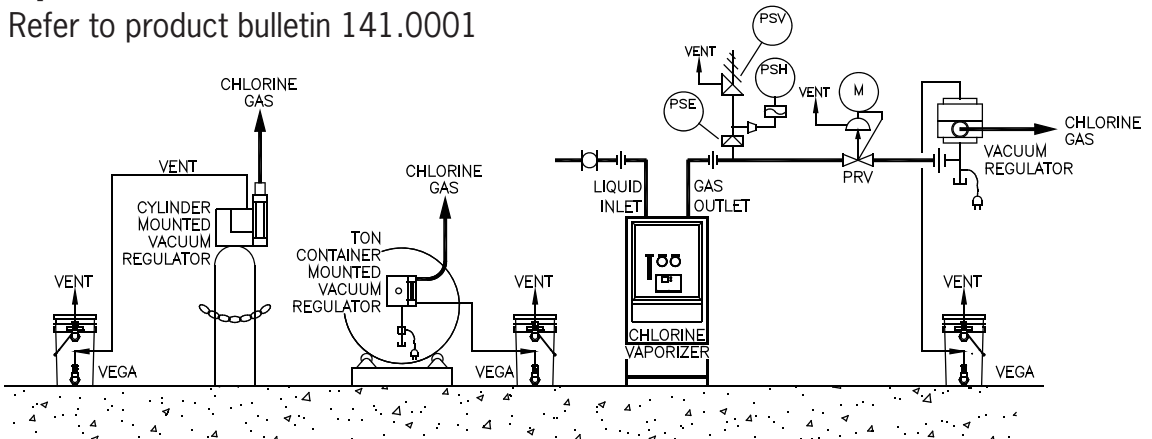

Severn Trent Services

3000 Advance Lane

Colmar, PA 18915

Telephone 215-997-4000

Fax 215-997-4062

marketing@severntrentservices.com

100.0001.12 APR/08